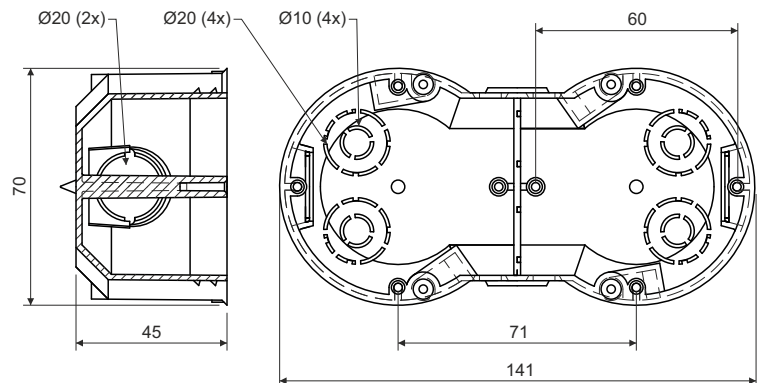
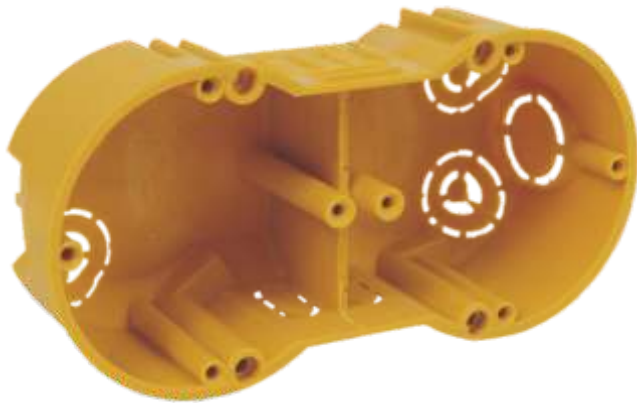

junction box

KP 64/2L

product description:

designed for distribution system with voltage 400 V and with maximum current 16 A
 for modern installations in combined frames (spacing 71 mm)
 significant rigidity makes device installation easier
 tips for marking hole centres for installation holes in the double wall
 mounting screws are fitted with a triple thread for quick installation
 when mounting, it is not necessary to countersink the plasterboard edge
 possibility to insert screwless terminals

material: PVC (Pb Free)

color: yellow

self-snuffing: yes, within 30 s

temperature resistance: -5 - +60 °C

flaming loop test: 850 °C

fire class for underlying material: A1-F

weight: 85 g

certification: EN 60 670-1

storage: ČSN 64 0090

configuration:

NA - two boxes packed in shrink foil and covered with label, screws included in the bag, packs aligned in cardboard - 50 pcs boxes

ST - individual boxes fitted with screws for mounting into double wall and covered with label, device screws are fitted in boxes; package - 50 pcs boxes

accessories:

cover VKP 64/2L

screwless terminal plates TYP015, TYP016, TYP017, TYP018

auxiliary tools:

saw-drill VPT 64

universal carrier VPTU

spring P1