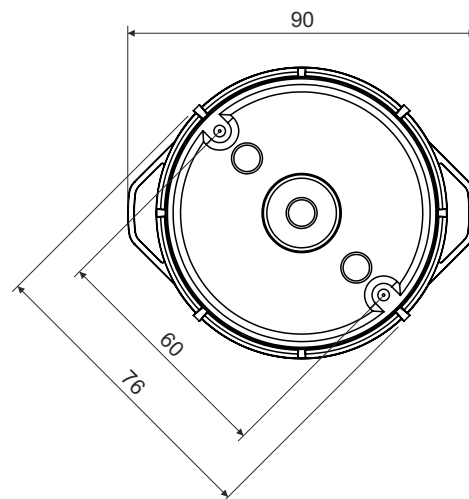
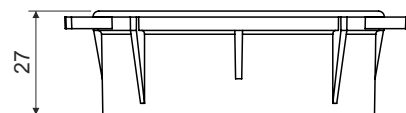

cover of the box into concrete

KBV-3

product description:

the cover is designed for mounting with body of the box KBT-1 or KBT-2
 cover is suitable when both sides of the wall shall be fitted with electronic devices against each other
 partition walls with 100 mm thickness: KBV-3 + KBT-1 + KBV-1 (or KBV-2)
 partition walls with 80 mm thickness: KBV-3 + KBT-2 + KBV-1 (or KBV-2)
 after hardening of the concrete, remove part of the rip-out part of the cover, making space for mounting
 cover allows to install the double-socket
 to adjust the height when applying additional plaster, you can use extending frame NRB 60/12 or NRB 60/24

material: PP (halogen-free)

color: gray

self-snuffing: no

temperature resistance: -5 - +60 °C (short-time +90 °C)

flaming loop test: 650 °C

fire class for underlying material: A1

weight: 27 g

certification: EN 60 670-1

storage: ČSN 64 0090

configuration: KB - 10 covers packed in foil, labeled; 120 covers in cardboard

