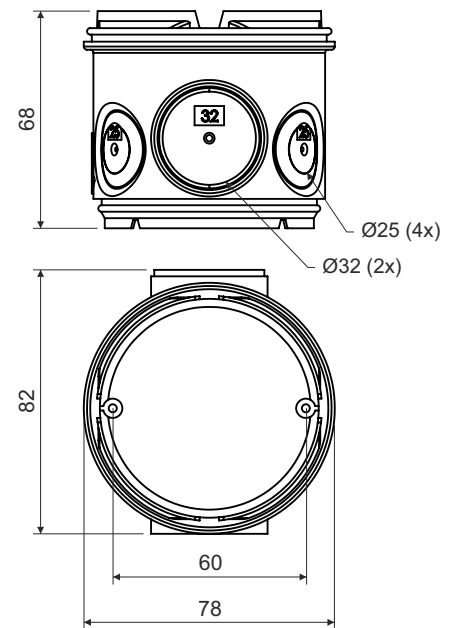

high body of the box into concrete
KBT-1

product description:

designed for distribution system with voltage 400 V

the body of the box is provided with a fixture for connection to the covers KBV-1, KBV-2 or KBV-3 and bottoms KBS-2 or KBS-3
the perimeter of the box body contains pre-marked holes to drill inlets for pipes of EN 25 and 32, inlets can easily be made in the desired locations using a drill and the respective drilling blade

possibility to join into and continuous series with and spacing of 80 mm

for devices with greater mounting depth

in combination with KBV-1 allows to install double-socket

the box can be fitted with terminal plate S-66, we recommend its mounting to the box body before assembly

material: PP (halogen-free)

color: orange

self-snuffing: no

temperature resistance: -5 - +60 °C (short-time +90 °C)

flaming loop test: 650 °C

fire class for underlying material: A1

weight: 44 g

certification: EN 60 670-1

storage: ČSN 64 0090

configuration: AB - 10 bodies of the box packed in foil, labeled; 100 bodies of the box in cardboard

high body of the box into concrete

Example of using one-sided mounting

Cover KBV-1 (KBV-2) is mounted to the fixed part of the casing. Then body KBT-1 is assembled together with the bottom piece KBS-2, prepared inputs for pipes and pushed to the already fixed cover KBV. Spacing pipe 8020 is inserted to support KBP-1 as well as the rod KBP-8. The back part of the set assembled in this way is slipped over the already mounted box and cover. Wiring pipes is installed to final set. The manufacturer recommends using a flexible pipes LPE (23xx/LPE-x).

The system can be completed from the side of the support KBP-1 which is mounted to the fixed part of the casing.

KBV-1 cover can be applied for assembly of and double socket.

KBV-2 allows connection with a spacing of 80 mm (two frames instrumentation Classic, Swing and Tango side by side). To increase the spacing of 88 mm is spacer KBE-1 (two frames apparatus Classic, Tango or Swing side by side with a gap of 8 mm).

Calculate the length of the spacer pipe and rods:

min. wall thickness = min. length set = 110 mm (L)

length of spacing rods (mm) = L - 20

length of spacing pipe 8020 (mm) = L - 85

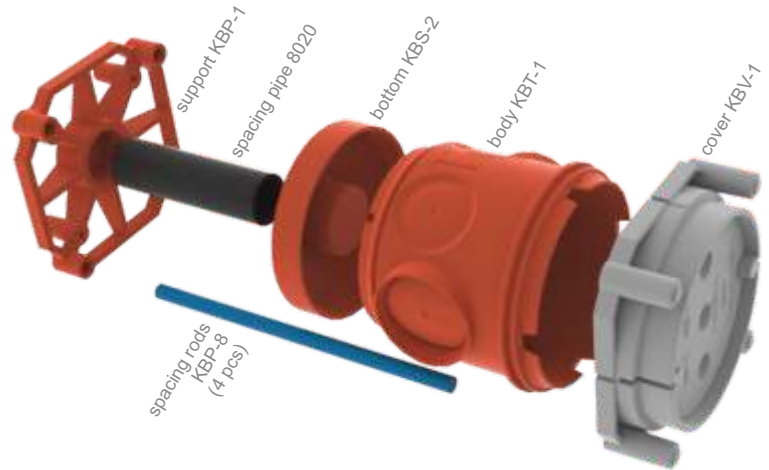

Example of using double-sided mounting

Cover KBV-1 (KBV-2) is mounted to the fixed part of the casing. Then body KBT-1 is assembled together with the bottom piece KBS-2, prepared inputs for pipes and pushed to the already fixed cover KBV. The other box is assembled, pipe 8020 is inserted as well as rod KBP-8. The back part of the set assembled in this way is slipped over the already mounted box and cover. Wiring pipes is installed to final set. The manufacturer recommends using a flexible pipes LPE (23xx/LPE-x).

KBV-1 cover can be applied for assembly of and double socket.

KBV-2 allows connection with a spacing of 80 mm (two frames instrumentation Classic, Swing and Tango side by side). To increase the spacing of 88 mm is spacer KBE-1 (two frames apparatus Classic, Tango or Swing side by side with a gap of 8 mm).

Calculate the length of the spacer pipe and rods:

min. wall thickness = min. length set = 185 mm (L)

length of spacing rods (mm) = L - 10

length of spacing pipe 8020 (mm) = L - 152

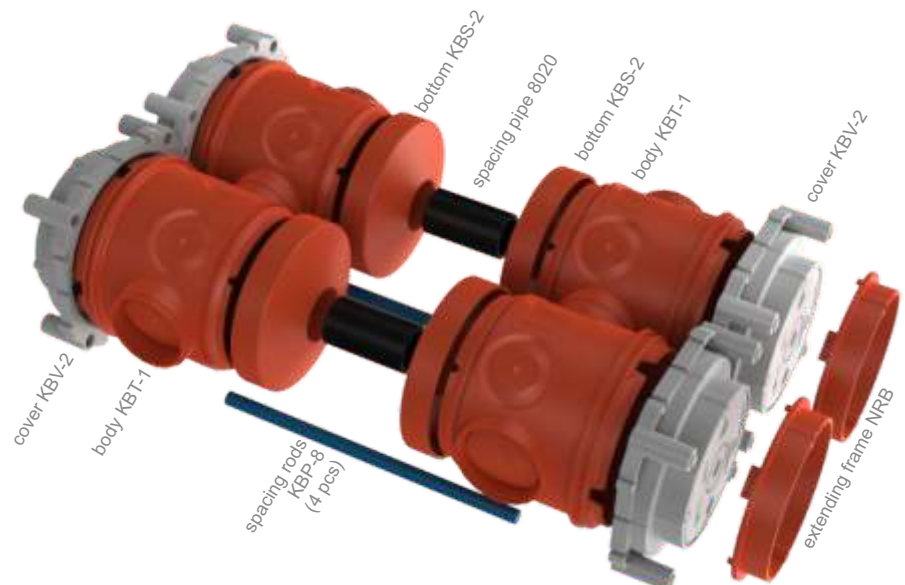

Before pouring concrete mixture, we recommend tying the system to reinforcements by means of draw bands and sealing passages around tubes using sealing material.

When the concrete mix is mature and the casing is dismantled, the break-off bottom of the cover KBV is removed and final electrical wiring is made inside the KBT-1 boxes.

The extending frames NBR 60/12 and NRB 60/24 are used to adjust the height of and box during subsequent application of and plaster (to cover KBV-1 is possible use frames NR 68/6 or NR 68/10).